

3-AXIS MAGNETIC FIELD SENSOR

W34

USER GUIDE



cma-science.nl

Short description

CMA Wireless 3-Axis Magnetic Field sensor W34 measures the strength and direction of magnetic fields within two ranges: -5 to 5 mT and -200 to 200 mT. It provides measurements of magnetic field strength along the X, Y, and Z axes.

The power button on the top of the sensor allows you to turn it on and off. The sensor is equipped with an OLED color display which shows sensor information and the measured values. This makes the sensor suitable to use as an independent measuring instrument. To improve visibility, you can rotate the sensor's screen 180 degrees by quickly pressing the power button twice.

By default, the sensor uses the ± 5 mT range. Press the power button briefly to select the ± 200 mT range. For accurate sensor detection in the Coach software, first select the desired range before connecting it.

The sensor can be used wirelessly via Bluetooth or wired via USB with the Coach 7 or Coach 7 lite programs/apps on computers (Windows and Mac), Chromebooks and mobile devices (Android and iOS).

How the sensor works

The Magnetic Field sensor uses two sensing elements which measure magnetic fields using the Hall effect. When a constant current flows through the Hall element and a perpendicular magnetic field is applied, the interaction between the magnetic field and the charge carriers in the material causes the charge carriers to accumulate on one side of the element. This accumulation creates a voltage difference, known as the Hall voltage. The Hall voltage is proportional to the strength of the magnetic field. By measuring this voltage, the Hall sensor can determine the strength and direction of the magnetic field.

The two Hall elements are situated at the end of the wand: one with the range of ± 5 mT (± 50 G) under the small circle, the other with the range of ± 200 mT (± 2000 G) under the small square.

When the wand is oriented in a specific direction, it detects the magnetic field at that location. The sensor measures the magnitude and polarity of the magnetic field along each axis. The magnitude of the field can be calculated in the Coach software as the square root of the sum of the squares of the measurements along all three axes.

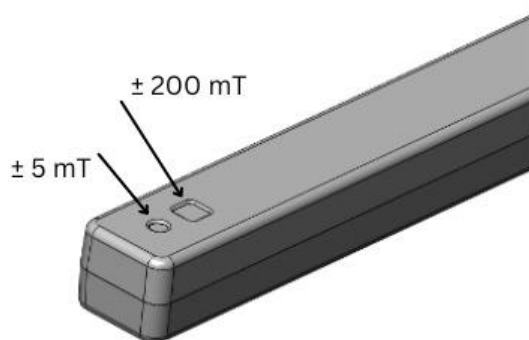

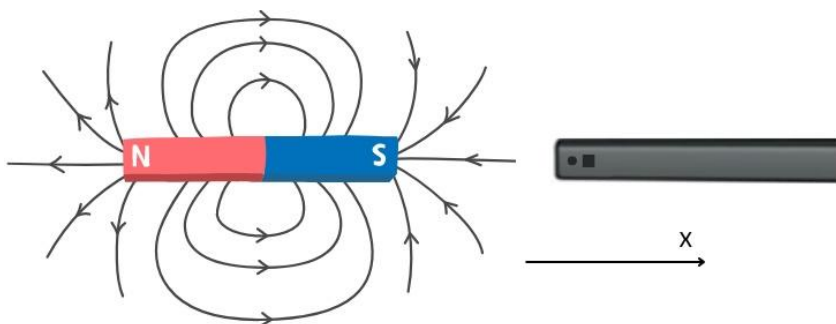

The measurement in the x-direction is positive when the South pole of a magnet is located in front of the wand and the Hall element, pointing in the x-direction, as shown in the image above.

The measurement in the y-direction is positive when the magnet is placed parallel to the wand, next to the Hall element, with its South pole pointing in the y-direction, as shown in the image on the right.

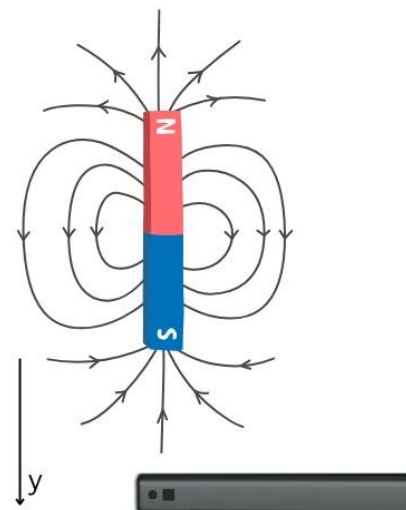

The measurement in the z-direction is positive when the magnet is located above the wand and Hall element with its South pole pointing downward (z-direction).

Calibration

The Magnetic Field sensor W34 converts measured magnetic field strength values into digital values. It comes with factory calibrations in mT. When using the Coach program, the pre-defined calibration can be adjusted by utilizing the **Set to Value** option. It's important to note that when this option is used, the values displayed in Coach and on the sensor's display may differ.

Software

You can use the Magnetic Field sensor W34 with Coach 7 or Coach 7 Lite (free) program on computers (Windows and Mac) or Coach 7 and Coach 7 Lite (free) app on mobile devices (Android and iOS). For Chromebooks, we offer a special Android app. The support for this wireless sensor is added starting from Coach version 7.11.



Check the CMA website for the latest installations.

https://cma-science.nl/downloads_en

Collecting data without Software connection

- Turn the Magnetic Field sensor on by pressing its power button.
- The sensor briefly displays its Bluetooth identification code. This ID code is also printed on the sticker located on the bottom side of the sensor box.
- Then the display shows:
 - the Bluetooth mode, 'Mobile' or 'PC'.
 Mobile indicates Bluetooth Low Energy mode which should be used when

working with mobile devices (Android, iOS), Chromebook and Apple computers.

PC indicates Bluetooth Classic which should be used for Windows computers.

- the battery level, and
- the current measured value.
- Now you can use the sensor as an independent measuring instrument.
- To turn the sensor off press and hold its power button for 3 sec. To save its battery the sensor automatically turns off after 5 minutes of inactivity (no connection to power, no communication).

Collecting data via the Bluetooth connection

Mobile devices, Chromebooks, and Apple computers

For mobile devices (Android, iOS), Chromebooks and Apple computers Bluetooth Low Energy technology is used for wireless communication. For these devices **do not pair** the sensor just use it directly in the Coach software.

- Turn the Magnetic Field sensor on.
- Ensure your sensor is set to 'Mobile' mode.
If the display shows in the top-left corner 'PC' first you must set the sensor to the Mobile mode. Turn off the sensor. Then press and hold the power button until the text 'Bluetooth mode Change Mobile' is shown, then release the button. The mode is set to 'Mobile' which means that Bluetooth Low Energy is used.
- Start the Coach 7 or Coach 7 Lite program/app.
- Select the Dashboard Activity 'Measurement with Wireless sensors'.
- Coach starts searching for sensors which are turned on and in the Mobile discovery mode. The found Bluetooth sensors appear in the list.
- Select the Magnetic Field sensor you want to connect to. If needed check the sensor's Bluetooth ID which is located on the sensor's bottom label.
- When the connection is established the Bluetooth symbol appears in the top-left corner of the sensor's display and the icon of the sensor appears showing the measured values.
- Now you are ready to use the Magnetic Field sensor for your measurement.

Windows computers

For Windows computers, Bluetooth Classic technology is used for wireless communication. Before you start to use the sensor for measurement in Coach **you have to pair it**.

- Turn the Magnetic Field sensor on.
- Ensure your sensor is set to 'PC' mode.
If the display shows in the top-left corner 'Mobile' first you must set the sensor to the PC mode. Turn off the sensor. Then press and hold the power button until the text 'Bluetooth mode Change PC' is shown, then release the button. The mode is set to 'PC' which means that Bluetooth Classic is used.

- Pair your sensor.
 - Go to the Windows Settings **Bluetooth and other devices** and select **Add Bluetooth or other devices**. Select **Bluetooth device**.
 - Windows looks for Bluetooth devices and after a while lists discovered devices. The wireless sensors are listed with their Bluetooth IDs.
 - Select the sensor you want to connect to. If needed check the sensor's Bluetooth ID which is located on the bottom label of your sensors.
 - When the connection is successfully established Windows indicates that the sensor is paired and ready to go.
 - Click **Done** to accept it. The sensor appears in the list of paired Bluetooth devices.
- Start the Coach 7 or Coach 7 Lite program.
- Select the Dashboard Activity 'Measurement with Wireless sensors'.
- Coach starts searching and displays the list with detected sensors, even if they are not paired.
- Select the sensor you want to connect to. If needed check the sensor's Bluetooth ID which is located on the sensor's bottom label. If the sensor was not paired yet Coach will force you to pair the sensor first via Windows Settings.
- When the connection is established the Bluetooth symbol appears in the top-left corner of the sensor's display and the icon of the sensor appears showing the measured values.
- Now you are ready to use the Magnetic Field sensor for your measurement.

Collecting data via the USB connection

For computers (Windows and Mac) the Magnetic field sensor can also be used as USB sensor.

- Turn the Magnetic Field sensor on.
- Use the provided USB cable to connect the sensor to a USB port.
- Start the Coach 7 or Coach 7 Lite program.
- Select the Dashboard Activity 'Measurement with Wireless sensors'.
- The connected USB sensor should be detected automatically, and its icon appears on the first empty sensor position in the Wireless sensors panel.
- When the connection is established the USB symbol appears in the top-left corner of the sensor's display and the icon shows measured data.
- Now you are ready to use the Magnetic Field sensor for your measurement.

Charging the batteries

An internal rechargeable battery (Li-Poly 3.7 V, 700 mAh) powers the sensor. The battery symbol located in the top-right corner of the sensor's display shows the battery level. When the battery level becomes critical, the battery gauge shows an empty battery. Use the provided cable to connect the sensor to a USB port for charging. A fully discharged battery requires up to 2 hours of charge time to become fully charged again. To prolong battery life, automatic power down turns the sensor off after 5 minutes of inactivity.

To replace the battery, use **only** the approved rechargeable batteries provided by CMA.

Suggested experiments

The Magnetic Field sensor can be used in various experiments such as:

- Measurements of the magnetic field near a permanent magnet.
- Measurements of the magnetic field near a current-carrying wire.
- Measurements of the magnetic field near or inside a coil or solenoid.
- The variation of the field when alternating current flows through a coil.

Magnetic field strength measurement

Magnetic field strength (also known as the *magnetic flux density*) is a measure of the force the magnetic field will exert on an electric current or another magnet.

In S.I. units magnetic field strength is expressed in teslas (T). In cgs units magnetic field strength is expressed in gauss (G).

$$1 \text{ G} = 1 \times 10^{-4} \text{ T} = 0.1 \text{ mT} \text{ and } 1 \text{ mT} = 10 \text{ G}$$

Below are given magnetic field strength values of exemplary magnetic sources.

Magnetic field strength in mT	Magnetic field source
$10^{-10} - 10^{-9}$	The human brain magnetic field
0.031 - 0.058	The Earth's magnetic field on its surface
2,5	The Earth's magnetic field in its core
5	A typical refrigerator magnet
10	A small iron magnet
200	A small neodymium-iron-boron (NIB) magnet
1500 - 3000	A medical magnetic resonance imaging electromagnet

Technical Specifications

<i>Sensor kind</i>	Digital, on-sensor digital conversion 16-bits for the ± 5 mT sensor 12-bits for the ± 200 mT sensor
<i>Measuring ranges</i>	-5 .. 5 mT -200 .. 200 mT
<i>Resolution</i>	0.001 mT 0.1 mT
<i>Display</i>	OLED 0.96" (128*64 px)
<i>Battery</i>	Li-Poly Rechargeable Battery (3,7 V 700 mAh)
<i>Battery life after full charge</i>	Approximately 12 hours Battery life varies by use, configuration, temperature, and many other factors; actual results will vary.
<i>Connection</i>	Bluetooth 5, Low Energy (Mac, Android, iOS) Bluetooth 2.1, Classic (Windows) USB 2.0 (type C)
<i>Bluetooth ID</i>	W34MAGN-xxx
<i>Wand length</i>	80 x 50 x 25 mm

Warranty

The Magnetic Field sensor W34 is warranted to be free from defects in materials and workmanship for a period of 3 years from the date of purchase provided that it has been used under normal laboratory conditions. This warranty does not apply if the sensor has been damaged by accident or misuse.

The sensor battery is consumable and is warranted to be free from defects in materials and workmanship for a period of 12 months from the date of purchase.

Discard batteries according to local regulations.



Note: *This product is to be used for educational purposes only.
It is not intended for industrial, medical, research, or commercial applications.*

Rev. 01.09.2025